

NATIONAL INSTITUTE OF TECHNOLOGY KARNATAKA, SURATHKAL

DEPARTMENT OF COMPUTER SCIENCE AND ENGINEERING
POST SRINIVASNAGAR, MANGALORE – 575 025 (D K)

Phone: (0824) 2474000.
E- mail: info@nitk.ac.in

Fax: (0824) 2474033
Website: <http://www.nitk.ac.in>

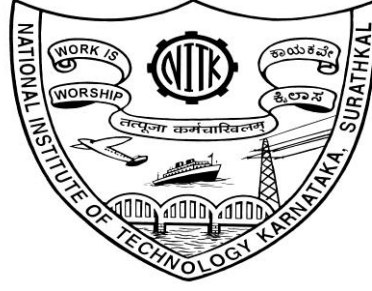

NOTICE INVITING QUOTATION

Notification No: NITK/CSE/OP-Cost/PUR/Stool/967/2023/4

Date: 09/08/2023

| | |
|--|--|
| Name of Goods | Wooden Stool |
| Estimated Amount: | Rs. 2,50,000 (Including GST) |
| Time for Supply of item after release of Purchase order | 30 Days |
| Document Download / Sale Start Date | 10/08/2023, 3.00 PM |
| Clarification Start Date | 10/08/2023, 3.00 PM |
| Clarification End Date | 18/08/2023, 3.00 PM |
| Bid Submission Start Date | 10/08/2023, 3.00 PM |
| Last Date for submission of bids | 04/09/2023 before 3.00 PM |
| Bid Opening Date | 05/09/2023, 3.00 PM |
| Address for Submission of bids | Dr. B. R. Chandavarkar Assistant Professor Dept. of Computer Science & Engineering NITK - Surathkal, PO Srinivasnagar, Mangalore - 575025 Dakshina Kannada District, Karnataka Contact No. : 0824-2473408 E-mail : brc@nitk.edu.in |



NATIONAL INSTITUTE OF TECHNOLOGY KARNATAKA, SURATHKAL
DEPARTMENT OF COMPUTER SCIENCE AND ENGINEERING
POST SRINIVASNAGAR, MANGALORE – 575 025

Phone: (0824) 2474000
E- mail: info@nitk.ac.in

Fax: (0824) 2474033
Website: http://www.nitk.ac.in

Notification No: NITK/CSE/OP-Cost/PUR/Stool/967/2023/4

Date: 09/08/2023

NOTICE INVITING QUOTATION (NIQ)

The National Institute of Technology Karnataka, Surathkal (in short – NITK, Surathkal) is an Institute Of National Importance Under Ministry of Education Govt of India, imparting Technical Education and engaged in Research Activities. It is proposed to procure the items for the departmental academic/research activities.

Sealed Quotations as per the Price Schedule given in this NIQ are invited for the following items subject to the terms and conditions, from the reputed manufacturers or its authorised dealers so as to reach on or before scheduled date and time. The quotations in the firm's Business letter head should be address to the "Director, NITK, Surathkal". The envelope shall be superscribed with the Quotation Notification Number and the Name of the Goods for which quotation is submitted.

| | |
|--|---------------------------------|
| Name of Goods | Wooden Stool |
| Estimated Amount: | Rs. 2,50,000 (Including GST) |
| Time for Supply of item after release of Purchase order | 30 Days |
| Document Download / Sale Start Date | 10/08/2023, 3.00 PM |
| Clarification Start Date | 10/08/2023, 3.00 PM |
| Clarification End Date | 18/08/2023, 3.00 PM |
| Bid Submission Start Date | 10/08/2023, 3.00 PM |
| Last Date for submission of bids | 04/09/2023 before 3.00 PM |
| Bid Opening Date | 05/09/2023, 3.00 PM |

**Sd/-
HOD**

Note: Institute shall not be responsible for any postal delay about non-receipt /non-delivery of the bids or due to wrong addressee.

SECTION-1
Terms and Conditions

1. The rates should be quoted for preferably FOR destination from supply within India.
2. The bidder shall indicate the excise duty exemption for the goods if applicable.
3. The rate quoted should be on unit basis. Taxes and other charges should be quoted separately, considering exemptions if any. The rate should be quoted in INR only
4. Rate quoted should be inclusive of Testing, commissioning and Installation of equipment and Training.
5. Payment: No advance payment will be made. Payment will be made only after the supply of the item in good and satisfactory condition and receipt of performance security by supplier.
6. Guarantee/Warranty period should be specified for the complete period should be specified in section 3 of this tender document.
7. Period requirement for the supply and installation of item should be specified in section 3 of this tender document.
8. Bidders must have a local service/supply center near Dakshina Kannada and Udupi regions and necessary documents and authorization letter for the same should be attached.
9. In case of dispute, the matter will be subject to Mangalore Jurisdiction only.

SECTION-2
SCHEDULE OF REQUIREMENTS, SPECIFICATIONS AND ALLIED DETAILS

[To be filled up by the Department / Centre of NITK, Surathkal]

Item(s) Name to be Procured : Wooden Stool

Brief Specifications of the Item(s)
(Attach Additional Sheet if necessary) : Attached

Quantity :60 no's

Any other details / requirement : Nil

Warranty Period required : 5 years

Delivery Schedule expected
after placement of Purchase order
(in Weeks) :4 weeks

SECTION 3
PRICE SCHEDULE

[To be used by the bidder for submission of the quotation]

-
1. Item Name :
 2. Specifications
(Conforming to Schedule of requirements
Enclose additional sheets if necessary) :
 3. Currency and Unit Price :
 4. Quantity :
 5. Item Cost (SI No. 3 * SI. No. 4) :
 6. Taxes and Other Charges :
(i) Specify the type of taxes and duties
in percentages and also in figures.
(ii) Specify Other Charges in figures.
 7. **Warranty Period** :
**(Conforming to the Schedule of
requirements)**
 8. Delivery Schedule :
(Conforming to the Schedule of requirements)
 9. Name and address of the Firm for
placing purchase order :
 10. Name and address of Indian authorized
agent (in case of imports only) :

Signature of the Bidder: _____

Name and Designation: _____

Business Address : _____

Place:

Date:

Seal of the Bidder's Firm

SECTION 4
CONTRACT FORM

[To be provided by the bidder in the business letter head]

1. (Name of the Supplier's Firm) hereby abide by the delivery schedule mentioned in this document for supply of the items if the purchase order is awarded.
2. The item will be supplied conforming to the specifications stated in this document without any defect and deviations.
3. Warranty will be given for the period mentioned in this document and service will be rendered to the satisfaction of NITK, Surathkal during this period.

Signature of the Bidder: _____

Name : _____

Business Address : _____

Place :
Date :

Seal of the Bidder's Firm

Department of Computer Science & Engineering, NITK-Surathkal

Purchase of Digital Lab Stools

Stool Quantity: 60 no's

Technical Specifications:

1. A first-quality Teak wood seating stool with 1.2 ft x 1.2 ft x 2.2 ft (L x B x H). The seat thickness of the stool is $\frac{3}{4}$ ". Thickness of the footrest is $\frac{3}{4}$ " x 2" (B x H) and the second footrest is 6" away from the first footrest of the same thickness and size. The stool leg thickness is $1\frac{3}{4}$ ".
2. All the internal and external surfaces of wood should be treated with sanding sealer mixed with thinner, after rubbing with zero-size sandpaper and applying sealer coat by way of spraying with the necessary compressor and after rubbing with steel wool, applying two coats of an approved shade of melamine Interior grade matt finish to provide anti-scratch and anti-stain properties (second coat of polish to be applied after drying of first coat) of approved make and approved colour to give good finish as per the specification.
3. After awarding the purchase order, the vendor is encouraged to visit the site and discuss it with the stakeholders. (The Exact size and quantity of stools are finalized at this time)
4. Customized modifications may require during manufacturing work.
5. All the wooden sizes are of finished thickness.
6. The work should be completed as per the detailed drawing and directions of the work in charge.
7. It is recommended to inspect the site/location during working hours before providing the final quote.
8. 5 years warranty period for the product.

LAB STOOL PLAN

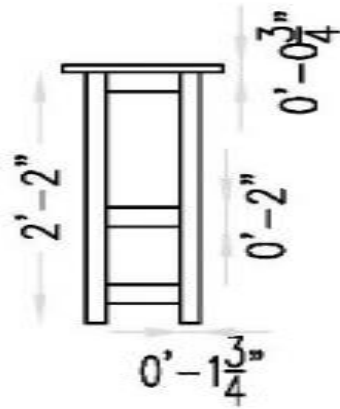

FRONT VIEW

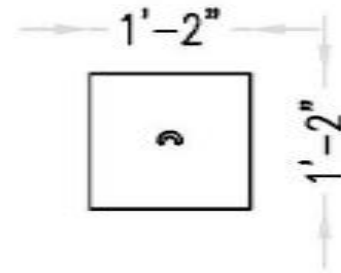

TOP VIEW

