



**POST SRINIVASNAGAR, MANGALURU – 575 025**

Phone: (0824) 2474 000. Fax: (0824) 2474 033/ 2474 039  
E- mail: registrar@nitk.ac.in Website: <http://www.nitk.ac.in>

No. 07/ NITK/ MECH- FUR/OH-35 / 2019-20 / B4

Date: 03 - 03 – 2020

**ADDENDUM - 01**

**Name of Work:** Manufacturing, Supply and installation furniture to Mechanical Engineering Department, NITK, Surathkal

**Tender Ref.No:** 07 / NITK / MECH- FUR / OH-35 / 2019-20 / B4 Dated: 07.02.2020

Attention is invited to the Open Tender ref no. No. 07/ NITK/ MECH- FUR/OH-35 / 2019-20 / B4. The following changes have been highlighted below in the red colour right hand side of the table. The below mentioned point is to be noted before quoting the same.

As existing in the Tender Document Specification	To be read as
<p><b><u>Conference Table (34-Seater - Similar to Godrej SENATE)</u></b> Tops: Work surface: Top thickness 31.6 (18mm + 12mm + 0.6 mm DL(both sides) + 0.4mm Membrane) Edge profile Waterfall Edge 10mm radius on top edge and 5mm at bottom. Understructure: Legs Modesty Panel: Made from 25mm PPB having a straight profile with half round edges and clad with 0.6mm thick Post Forming laminate. Overall thickness of leg is 26.2mm. Made from PLT (Prelaminated Twin) boards of 18mm thick. Wire Manager: Wire Carrier Carrier Cover: Made from 0.6mm thick CRCA painted. Made of 12mm thick. MDF Painted all over. Substrate: MDF Skin: PVC Membrane foil (0.4mm thk) clad on the substrate MDF using PU glue for better adhesion. This foil is pre-coated with layer of polyurethane for better scratch resistance Table Size: Width = 12 Meters (approx.) Depth = 1.43 Meters (approx..) Seating Capacity: 34-Seater ( 2Nos Single Seater, 14 Nos Two Seater &amp; 2Nos Two Seater (Half Circle )</p>	<p><b><u>Conference Table (34-Seater - Similar to Godrej SENATE)</u></b> Tops: Work surface: Top thickness 31.6 (18mm + 12mm + 0.6 mm DL(both sides) + 0.4mm Membrane) Edge profile Waterfall Edge 10mm radius on top edge and 5mm at bottom. Understructure: Legs Modesty Panel: Made from 25mm PPB having a straight profile with half round edges and clad with 0.6mm thick Post Forming laminate. Overall thickness of leg is 26.2mm. Made from PLT (Prelaminated Twin) boards of 18mm thick. Wire Manager: Wire Carrier Carrier Cover: Made from 0.6mm thick CRCA painted. Made of 12mm thick. MDF Painted all over. Substrate: MDF Skin: PVC Membrane foil (0.4mm thk) clad on the substrate MDF using PU glue for better adhesion. This foil is pre-coated with layer of polyurethane for better scratch resistance Table Size: <b>Width = 1426 mm (approx.)</b> <b>Depth = 750mm (approx.)</b> Seating Capacity: 34-Seater ( 2Nos Single Seater, 14 Nos Two Seater &amp; 2Nos Two Seater (Half Circle )</p>

**Heavy Duty Table** Length – 1828 mm (6ft), Width 3ft, Height 853 mm (2.8 ft) with granite Top. Made of finely polished (18 mm) thick jet-black Granite top with rounded edge

**Heavy Duty Table** Length – 1828 mm (6ft), Width **914.4 mm (3ft)**, Height 853 mm (2.8 ft) with granite Top. Made of finely polished (18 mm) thick jet-black Granite top with rounded edge

**Wooden Bench**

Supplying of wooden Bench of size **2.15 m x 0.45 m x 0.45 m** made by using well seasoned **First class Mahogany wood(Swietenia Maerophylla)**, free from knots, with 6 numbers of legs of size 60mm x 60mm. The Bench should be provided 30mm thick wooden plank for seat & 20mm thick wooden plank for back rest. 40 mm x 60 mm size wood for seat supports. 60 mm x 30 mm size wood for back supports. 40 mm x 40 mm size wood for bottom leg support ties. All the wooden sizes are finished thickness before applying melamine spray. All the wooden surfaces should be treated with sanding sealer mixed with thinner, after rubbing with zero size sand paper and applying sealer coat by way of spraying with necessary compressor and after rubbing with steel wool, applying two coats of approved shade of melamine spray polish Interior grade matt finish to provide anti - scratch and anti - strain properties (second coat of spray polish to be applied after drying of first coat) of approved make and colour to give good finish as per the specification. **Size : 2.15 m (L) x 0.45 m (W) x 0.45 m (H)**

**Wooden Bench**

Supplying of wooden Bench of size 2.15 m x 0.45 m x 0.45 mm made by using well seasoned **First class Mahogany wood(Swietenia Maerophylla)**, free from knots, with 6 numbers of legs of size 60mm x 60mm. The Bench should be provided 30mm thick wooden plank for seat & 20mm thick wooden plank for back rest. 40 mm x 60 mm size wood for seat supports. 60 mm x 30 mm size wood for back supports. 40 mm x 40 mm size wood for bottom leg support ties. All the wooden sizes are finished thickness before applying melamine spray. All the wooden surfaces should be treated with sanding sealer mixed with thinner, after rubbing with zero size sand paper and applying sealer coat by way of spraying with necessary compressor and after rubbing with steel wool, applying two coats of approved shade of melamine spray polish Interior grade matt finish to provide anti -scratch and anti -strain properties (second coat of spray polish to be applied after drying of first coat) of approved make and colour to give good finish as per the specification. **Size is 2.15M (L) X 0.45M (W) X 0.93M(H)**

**Wooden Desk**

Supplying of Class room Wooden Desks of size **2.15 m x 0.45 m x 0.75 m**, made by using well-seasoned **First class Mahogany wood (Swietenia Maerophylla)**, free from knots, with 6 numbers of legs of size 60mm x 60mm. The Desk top & bottom planks should be 25 mm thick Mahogany wood planks. Leg support ties & Central foot rest of size 40 mm x 50 mm. Top three sides support planks should be 25mm thick. All the wooden sizes are finished thickness before applying melamine spray polish. All the wooden surfaces should be treated with sanding sealer mixed with thinner, after rubbing with zero size sand paper and applying sealer coat by way of spraying with necessary compressor and after rubbing with steel wool, applying two coats of approved shade of melamine spray polish Interior grade matt finish to provide anti - scratch and anti - strain properties (second coat of melamine spray polish to be applied after drying of first coat) of approved make colour to give good finish as per the specification. **Size : 2.15 m (L) x 0.45 m (W) x 0.75 m (H)**

**Wooden Desk**

Wooden Desk Supplying of Class room Wooden Desks of size 2.15 m x 0.45 m x 0.75 m, made by using well-seasoned **First class Mahogany wood(Swietenia Maerophylla)**, free from knots, with 6 numbers of legs of size 60mm x 60mm. The Desk top & bottom planks should be 25 mm thick Mahogany wood planks. Leg support ties & Central foot rest of size **40 mm x 50 mm**. Top three sides support planks should be 25mm thick. All the wooden sizes are finished thickness before applying melamine spray polish. All the wooden surfaces should be treated with sanding sealer mixed with thinner, after rubbing with zero size sand paper and applying sealer coat by way of spraying with necessary compressor and after rubbing with steel wool, applying two coats of approved shade of melamine spray polish Interior grade matt finish to provide anti -scratch and anti -strain properties (second coat of melamine spray polish to be applied after drying of first coat) of approved make colour to give good finish as per the specification. **Size : 2.15 m (L) x 0.45 m (W) x 0.75 m (H)**

### Wooden Desk

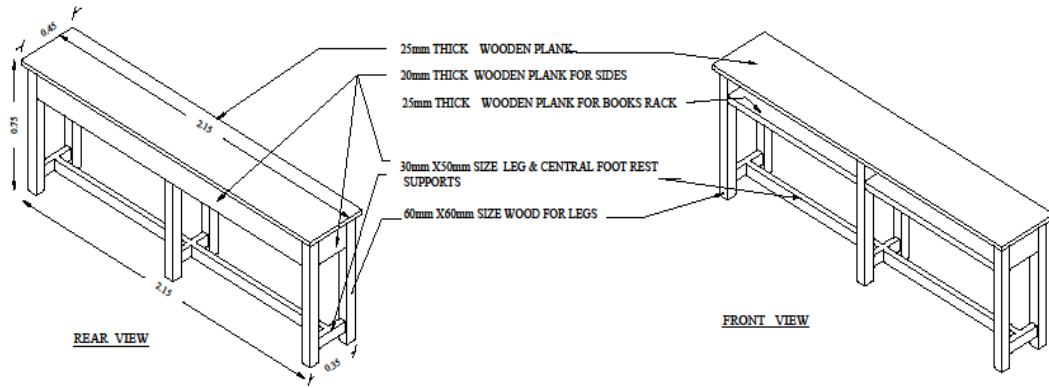

### WOODEN DESK

SIZE : 2.15m (L) X 0.45m (W) X 0.75m (H)

### Wooden Desk

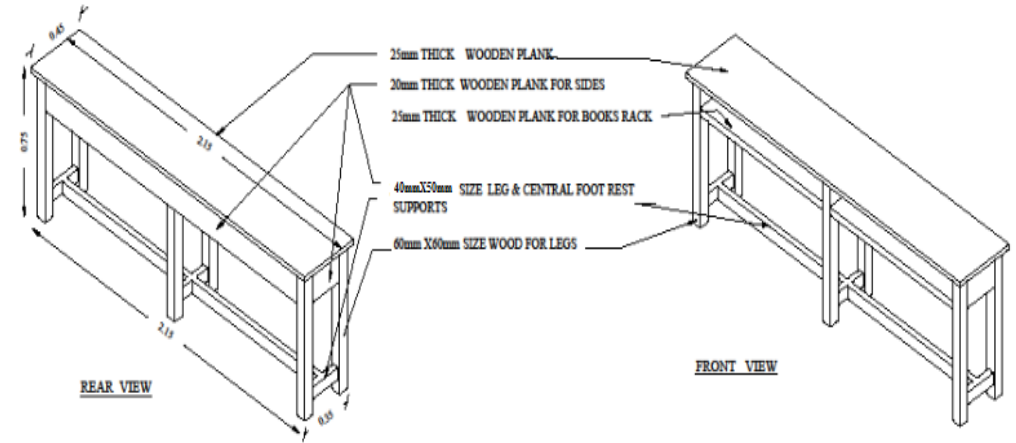

### WOODEN DESK

SIZE : 2.15m (L) X 0.45m (W) X 0.75m (H)

40MMx50MM SIZE LEG AND CENTRAL FOOTREST

The remaining specifications and terms & conditions of the tender are remain same.

Yours sincerely

Sd/-

**REGISTRAR**

NITK, Surathkal

